

01. Wood hitch system

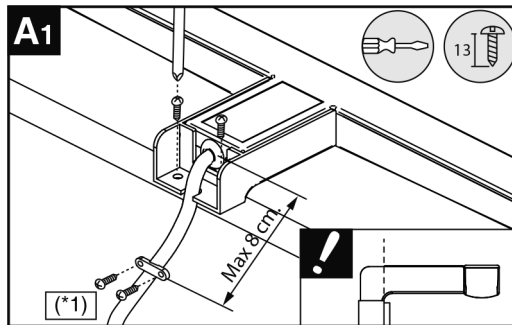

02. Mirror cabinet hitch system

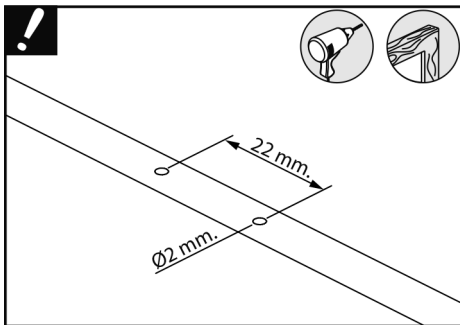
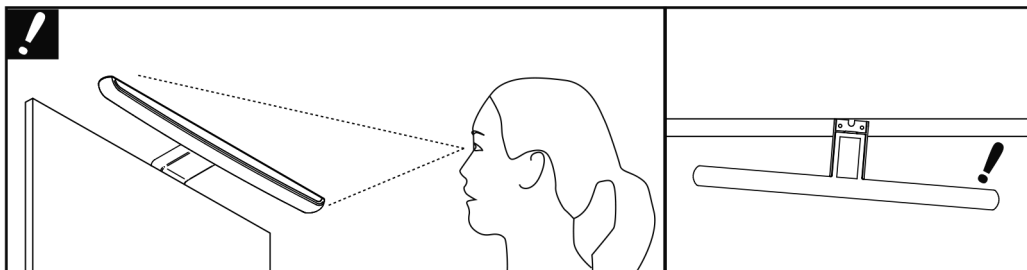
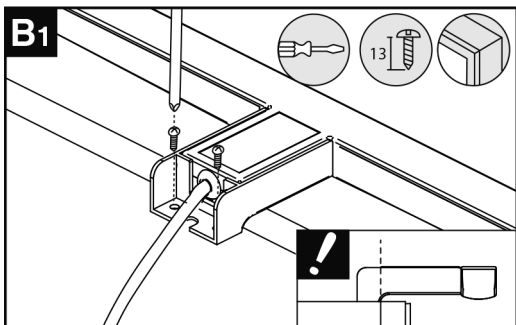

03. Connection

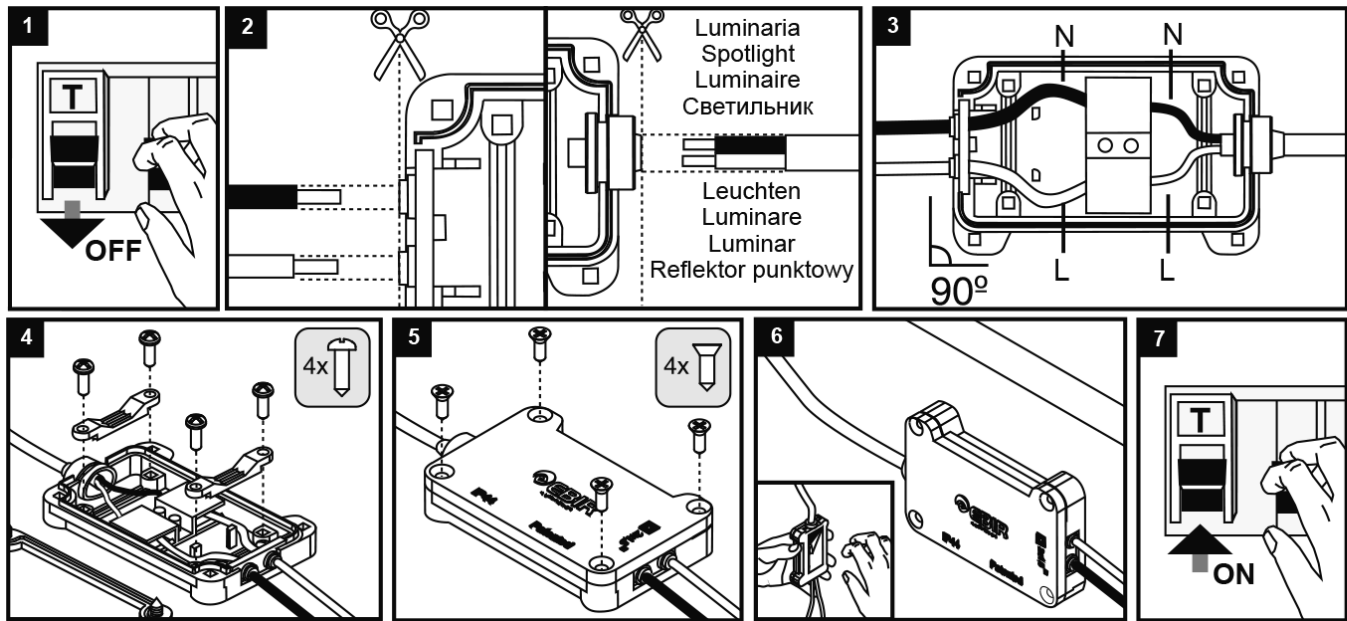

1. Disconnect the main switch of the electrical installation.
2. Cut the rubber bands of the connection box to a size slightly smaller than the diameter of the cables.
3. Connect the wires to the connection block inside the box.
4. Screw the cable glands holding the cables well.
5. Close the connection box.
6. Stick the connection box on the mirror.
7. Connect the main switch of the electrical installation.

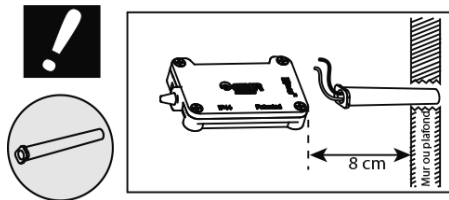

*Note 1: The length of the power supply cables must not exceed 8 cm.